

Podcasting Using Sanyo Digital Recorders

Introduction

The Sanyo digital recorder is available for instructors to record class lectures. These lectures can then be transferred to a PC to be pod-casted on Blackboard making them easily accessible to students.

The features include:

- 256 MB flash memory
- Built-in FM stereo
- Records up to __ hours of MP3 audio
- Six preset recording modes
- Holds up to 60 MP3 audio files
- Voice-activated recording
- May be used as USB flash drive for data storage
- Approximately 6 hours battery life on a single AAA battery

Controls

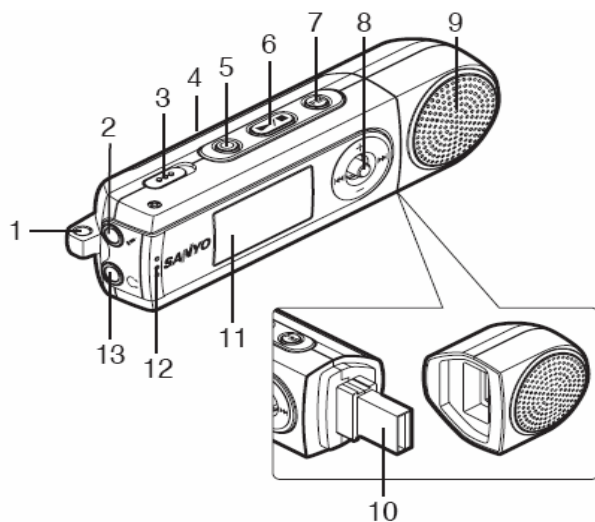

- | | |
|-----------------------------|------------------------------|
| 1. Necklace connection hole | 2. External stereo mic. jack |
| 3. Hold switch | 4. Battery compartment lid |
| 5. Sound, Record/Pause | 6. Power, Play/Stop button |
| 7. Erase/Memory, Repeat/FM | 8. Jog button |
| 9. Speaker | 10. USB terminal |
| 11. LCD display | 12. Built-in microphone |
| 13. Headphones jack | |

General Instructions Before Operation

Turning the power on and off

Press the play/stop (▶■) button for 2 seconds to turn the device on or off. While powering on, the LCD display will briefly read, "Loading..." then "WELCOME" then the last selected file/folder or FM station appears.

General Instructions Before Operation (Cont.)

Hold function prevents operation from stopping by accidentally pressing a button.



Set the HOLD switch to the right. "HOLD" appears and the hold function is engaged. Set the HOLD switch to the left to disengage the function.

Switching function mode

In the stop mode (press STOP), whenever you press the FM (REPEAT/FM) button long, the mode will be switched between player and FM mode.



Player mode

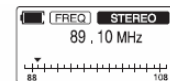

FM mode

To adjust the volume

Press the Jog button to + or – direction.

Preparation for Recording

Setting up recording quality (file format, recording quality and maximum recording time)

1. In the stop mode, press in the Jog button for at least 2 seconds and the first stage menu appears.
2. Press the Jog button to ◀◀ or ▶▶ direction to select "RECORD", then press in the Jog button in the center and the second stage menu appears.

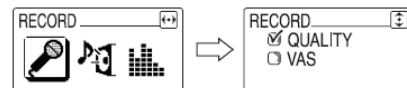

3. Press the Jog button to + or – direction to select "QUALITY", then press in the Jog button. The third stage menu appears.



4. Press the Jog button to + or – direction to select the desired recording quality, then press in the Jog button. The second stage menu "RECORD" returns
5. Press in the Jog button for at least 2 seconds to quit the menu setting mode.

Setting up VAS (Voice Activated System) recording

VAS stops the recording temporarily when the voice is too low or there is no detected sound.

1. Select "VAS" (steps 2 and 3 above) then press in the Jog button.
2. Press the Jog button to + or – direction to select "ON" (to activate VAS mode) or "OFF" (for normal recording mode), then press in the Jog button.
3. Press in the Jog button for at least 2 seconds to quit the menu setting mode.

Recording quality: Recording time (approx.)

16kbps: 35 hr (Mono), 32kbps: 17 hr, 30 min. (Mono), 64kbps: 8 hr, 40 min. (Stereo)
96kbps: 6 hr (Stereo), 128kbps: 4 hr, 20 min. (Stereo), 192kbps: 3 hr (Stereo)

Podcasting Using Sanyo Digital Recorders

Continued

Recording

1. Press the ● (REC/PAUSE) button in the stop mode to start recording or pause recording.

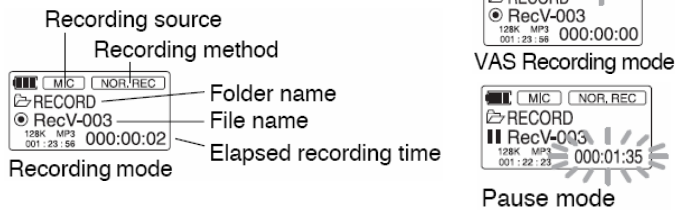

- If you press the Jog button to ►► direction during recording, the file number is added automatically and recording continues.
2. To stop recording, press the ►■ (PLAY/STOP) button.

Playback

1. Select the desired file/folder using the Jog button.
 - Move up
 - Move to upper folder
 - Move to sub-folder
 - Move down
2. Press the ►■ (PLAY/STOP) button to play back the selected file, as well as to stop the selected file.
 - If only a folder is selected, playback starts from the first file in the selected folder. "No File!" will appear if no playable file is in the folder.
3. To skip to the next or previous file press the Jog button once to ►► or ◀◀ direction during playback. To fast forward or reverse, press the button either way and hold it during playback.

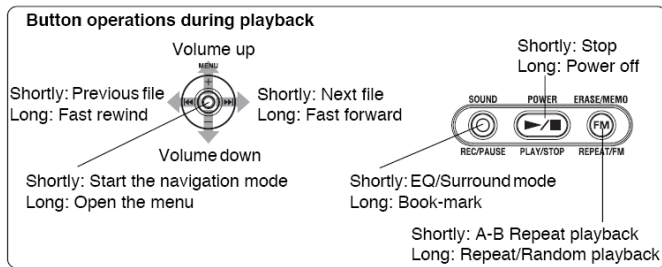
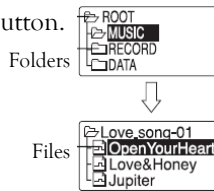

Connecting the unit to your PC

The USB terminal can be connected directly to your PC. Remove the speaker and connect in accordance with the direction of the terminal.

Selecting the action Windows is to take

After the connection, a screen will appear. Click [Take no action] option and click [Ok]

NOTE: Do not disconnect during data transfer.

Displaying by Explorer

To start Explorer double-click [My Computer] icon on your desktop. An icon for a Removable Disk will appear in the My Computer window when the unit is connected to your PC.

Displaying by Explorer (Cont.)

[RECORD] folder

Files recorded using the unit are stored here.

- Files recorded from the microphone are stored with the name "RECV_XXX(file number).MP3"
- Files recorded from the FM are stored with the name "RECF_XXX(file number).MP3"
- The RECORD folder can hold up to 999 files.

[MUSIC] folder

Files transferred from your PC are stored in this folder.

- The MUSIC folder can hold up to 500 files
- There is no set format for file names which are transferred, but they MUST be MP3 or WMA files.

[DATA] folder

This folder stores data files (Excel, Word, etc.) as a Removable Disc

Transferring data using Explorer

Start Explorer (see "Displaying by Explorer" instructions)

Copying files to your PC

Select the files you wish to copy on the Removable Disk and drag and drop them into a folder of your choice on your PC.

Copying files to the unit

Select the files to copy and drag and drop them into the appropriate folder associated with that file type.

Note:

- Repeatedly transferring data from your PC and/or deleting data will cause the transfer rate to slow. If this happens, turn the unit off and on.
- Some MP3/WMA files may not be able to be played on this unit.

Blackboard Podcasting Instructions

Podcast is an application that allows instructors to create and share podcasts within their courses. When instructors create new Podcast episodes, they will appear automatically in the Podcast tool within the Course Tools area of the course. The Podcast tool displays all Podcast episodes within the course in chronological order. Students subscribe to the course Podcast either in iTunes or in any other podcatcher from within the Podcast tool.

Creating podcast episodes:

1. Access the Control Panel.
2. Choose the Content Area (e.g., Course Documents, Assignments, etc.) where you wish to create the episode.
3. Select "Podcast Episode" from the dropdown list in the right corner of the action bar then click the Go button to create the episode.
4. To configure, enter a name for the podcast and a brief description.
5. **Attach a local file:** Click Browse and locate the file transferred from the recorder to the PC
6. To set the availability of the podcast episode for students, use the date and time ranges located in the Options section.

Listening to podcast episodes

Within the course, select the Listen link and it will open within the default media player on the user's computer.